

Extincteurs Poudre ABC Pression Permanente
Gamme EXPER – 6kg/9kg
ABC Powder Stored Pressure
Extinguishers EXPER Range 6Kg/9Kg

<ul style="list-style-type: none"> • Mode d'extinction : • Action par étouffement sur les feux de classe A grâce à la formation d'un vernis liquide qui isole les surfaces chaudes de l'oxygène et des gaz inflammables, empêchant la reprise du feu. • Action inhibitrice sur les feux de classe B et C. 	<p align="center">Efficace sur</p>  <p align="center">Feux de solides classe A Feux de liquides classe B Feux de gaz classe C</p>
<ul style="list-style-type: none"> • Extinction Mode : • <i>Suffocating action on class A fires thanks to the creation of a liquid varnish which keeps the hot surfaces away from oxygen and flammable gas, thus preventing the reburning.</i> • <i>Inhibition action on class B and C fires.</i> 	<p align="center">Efficient on</p>  <p align="center">Class A fires involving solids Class B fires involving liquids Class C fires involving gas</p>

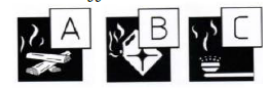

Photos non contractuelles / Non contractual pictures

Caractéristiques techniques / Technical Features		
Extincteur Type / Extinguisher Model	GT006 ABC-1 / GT006 ABC-2	GT009 ABC-1 / GT009 ABC-2
N° de certification EN3-7 / EN3-7 Certification N°	EP6 132 788 EP6 132 789	EP9 132 790 EP9 132 791
Capacité en charge / Loading Capacity	6 kg	9 kg
Agent extincteur / Extinguishing Agent	Poudre HJ ABC UNIVERSAL ou/or ABC 40/P1124	
Foyers / Fire Rating	43A-233B-C	55A-233B-C
Poids en ordre de marche / Full Weight	9,3 kg	13,7 kg
Hauteur / Height	533 mm	557 mm
Largeur hors tout / Overall Width	285 mm	290 mm
Diamètre / Diameter	154 mm	182 mm
Agent propulseur / Propelling Agent	Azote à 15 bars	
Support transport / Vehicle Bracket	en option / optional	
Support mural / Wall Bracket	de série / included	
Socle / Base	de série / included	
Température d'utilisation / Operating temperature	-30°C +60°C	-30°C +60°C
Temps de fonctionnement / Discharge time	20,27s 27,47s	26,82s 28,54s
Emballage L x l x H / Packaging L x l x H	170 x 170 x 555	190 x 190 x 590
Palettisation L x l x H / Palletisation L x W x H (nbre d'extincteurs par palette/extinguishers per pallet)	1100 x 1100 x 1100 (60 appareils/units)	1000 x 1200 x 1100 (50 appareils/units)
Palettisation gerbée / Palletisation stacking	(60 appareils/units)	(50 appareils/units)
Poids de la palette / Weight of pallet	582 ± 5 kg	705 ± 5 kg

* CECA ABC40 = ABC40/P1124

V 1.03

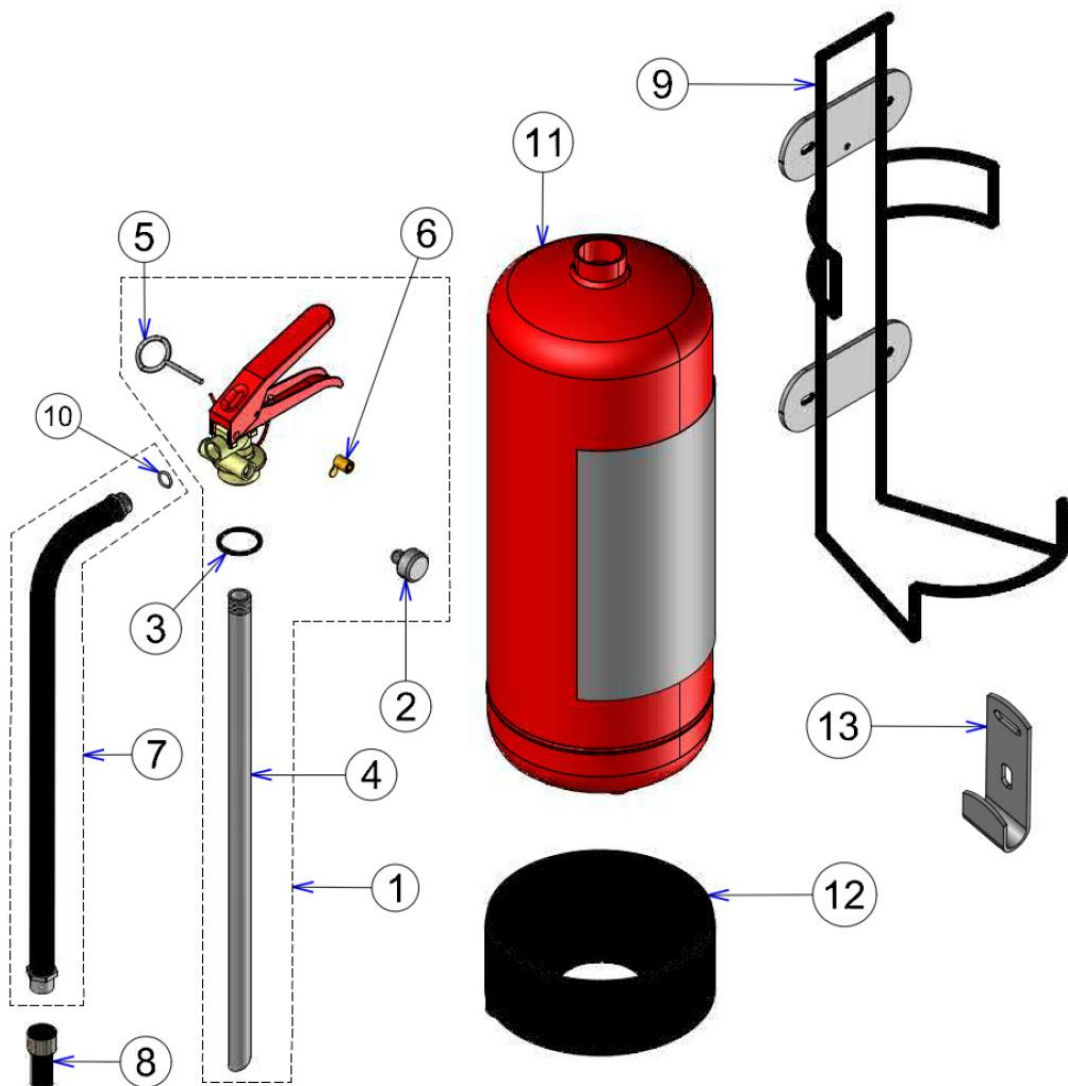
Pièces détachées / Parts List

 Couple de serrage de la vanne 30-55 DaN.m - *Fastening couple of the valve 30-55 DaN.m*

Extincteur Type / Extinguisher Model	GT006 ABC-1 GT006 ABC-2	GT009 ABC-1 GT009 ABC-2
Références Appareils / Reference	A022246	A022245
N° de certification EN3-7 / EN3-7 Certification N°	EP6 132 788 EP6 132 789	EP9 132 790 EP9 132 791
Capacité poudre polyvalente / Powder Capacity	6 kg	9 kg
N° Désignation Pièces / Description	Références Pièces / Ref. N°	
1 Vanne complète / Complete Valve	A022626	A022627
2 Indicateur pression / Pressure Gauge		A022628
3 Joint de tête / Cap o-ring		A022610
4 Tube plongeur / Dip tube	A022629	A022630
5 Goupille de sécurité / Safety Pin		A022631
6 Scellé plastique / Plastic Seal		A022614
7 Lance nue / Discharge Hose	A022615	A022616
8 Diffuseur / Nozzle		A022632
9 Support transport / Transport bracket	A022633	A022634
10 Joint de lance / Hose o-ring		A022620
11 Corps d'extincteur / Extinguisher body	A022635	A022636
12 Socle embase noir / Black base	A022637	A022638
13 Support mural / Wall bracket		A022625

V 1.03